

**RIGHR ANGLE MALE DUPLEX RECEPTACLE**

**R197.260.F00**

Series : **SMB**  
**CARLOCK**

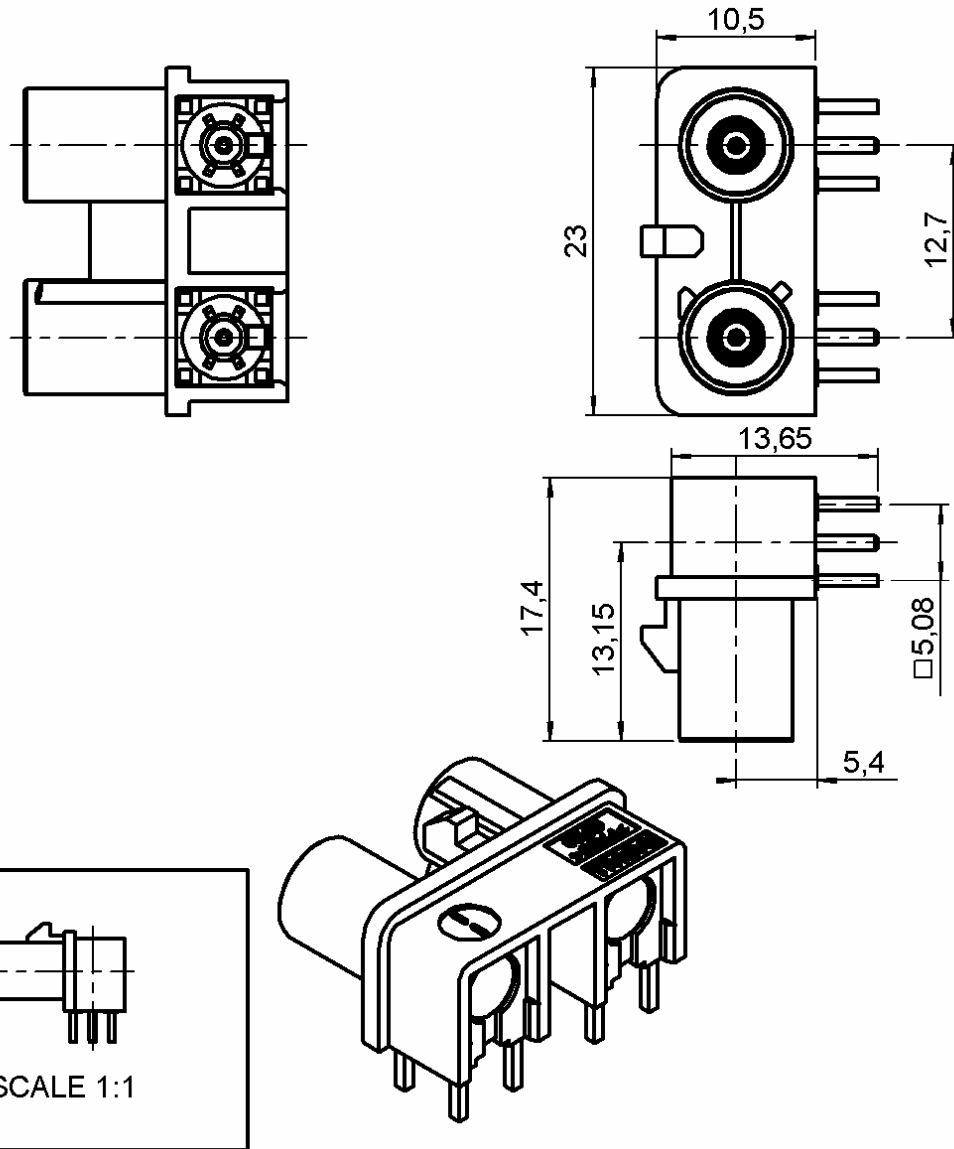

All dimensions are in mm.

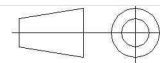

COMPONENTS	MATERIALS	PLATINGS (µm)
BODY	BRASS	NICKEL 2
CENTER CONTACT	BRASS	GOLD OVER NICKEL
OUTER CONTACT	-	-
INSULATOR	PTFE	-
GASKET	-	-
OTHERS PARTS	BRASS	BBR 2
-	-	-
HOUSING	PA 6.6 30% GF	-

**UL CLASSIFICATION :** UL 94 V-2      **COLOR :** BROWN (RAL 8011) For coding F\*

**Issue :** 0213 A

In the effort to improve our products, we reserve the right to make changes judged to be necessary.



**RIGHR ANGLE MALE DUPLEX RECEPTACLE**

**R197.260.F00**

Series : **SMB**  
**CARLOCK**

**PACKAGING**

**SPECIFICATION**

Standard	Unit	Other
<b>50</b>	<b>'W' option</b>	<b>Contact us</b>

-

**ELECTRICAL CHARACTERISTICS**

**ENVIRONMENTAL**

Impedance	<b>50</b>	$\Omega$
Frequency	<b>0.2</b>	GHz
VSWR	<b>1.2 + 0.000</b>	x F(GHz) Maxi
Insertion loss	<b>0.25</b>	$\sqrt{F(GHz)}$ dB Maxi
RF leakage	- ( - )	- F(GHz)) dB Maxi
Voltage rating	<b>335</b>	Veff Maxi
Dielectric withstanding voltage	<b>1000</b>	Veff mini
Insulation resistance	<b>1000</b>	M $\Omega$ mini

Operating temperature	<b>-40/+110</b>	$^{\circ}$ C
Hermetic seal	<b>NA</b>	Atm.cm3/s
Panel leakage	<b>NA</b>	

**OTHERS CHARACTERISTICS**

Assembly instruction

Others :

\*According to FAKRA specification

**MECHANICAL CHARACTERISTICS**

Center contact retention		
Axial force – Mating end	<b>10</b>	N mini
Axial force – Opposite end	<b>10</b>	N mini
Torque	<b>NA</b>	N.cm mini
Recommended torque		
Mating	<b>NA</b>	N.cm
Panel nut	<b>NA</b>	N.cm
Mating life	<b>100</b>	Cycles mini
Weight	<b>6.500</b>	g

Issue : 0213 A

In the effort to improve our products, we reserve the right to make changes judged to be necessary.

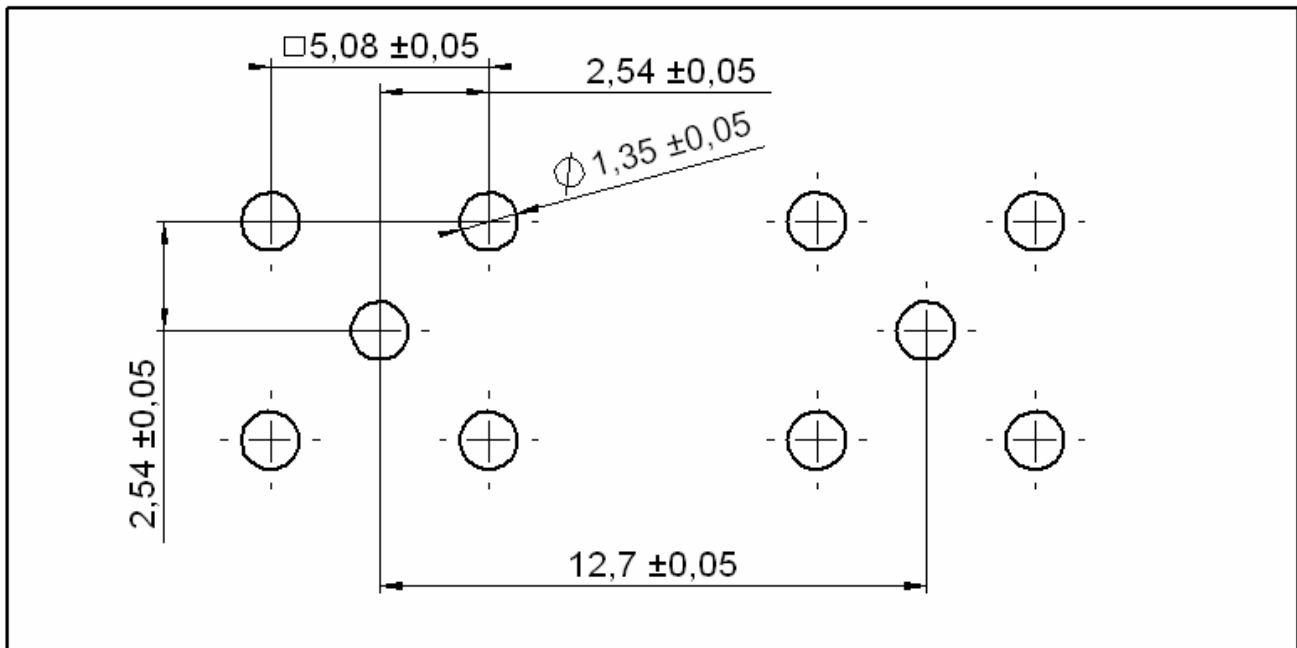

## RIGHT ANGLE MALE DUPLEX RECEPTACLE

**R197.260.F00**Series : SMB  
CARLOCK***RECOMMENDED PCB PATTERN***

Use a activated flux for PCB legs solder

Issue : 0213 A

In the effort to improve our products, we reserve the right to make changes judged to be necessary.

